

 Panadent Corporation
 580 S. Rancho Avenue • Colton, California 92324, USA
 Tel: (909) 783-1841 • USA & Canada (800) 368-9777

These instructions apply to the following items:

REF 4000, 4130

Includes:

4015 

The following procedure is followed when Panadent *Bite-Tab* compound discs are used for bite-fork registration.

Bend backing-sheet sharply at extreme printed end of *Bite-Tab* strip to free end of strip so it can be grasped with index finger and thumb. Peel *Bite-Tab* strip away from backing sheet. Do not touch adhesive under end of tab where compound is located.

Hold *Bite-Tab* with thumb and index finger at lateral edges (arrows). Fold printed end of tab back (adhesive to adhesive) at dotted line. This fold-back produces a non-stick flap for easy removal of Tab after maxillary cast has been mounted. Do not touch adhesive under *Bite-Tab* since powder from latex gloves will prevent *Bite-Tab* from adhering to bite-fork.

Press one *Bite-Tab* at each of the following six locations: left molar, right molar, and incisor on upper and lower surfaces (six tabs) on clean, dry bite-fork.

Place intra oral end of bite-fork in hot water (125°F / 40°C) for about one half to one minute to soften *Bite-Tab* compound discs. If tap water is not hot enough, hot coffee or coffee water will work well to soften compound.

ATTENTION: Do not place bite-fork in regular water-bath since wax residues and oils in water-bath will prevent *Bite-Tabs* from adhering to bite-fork.

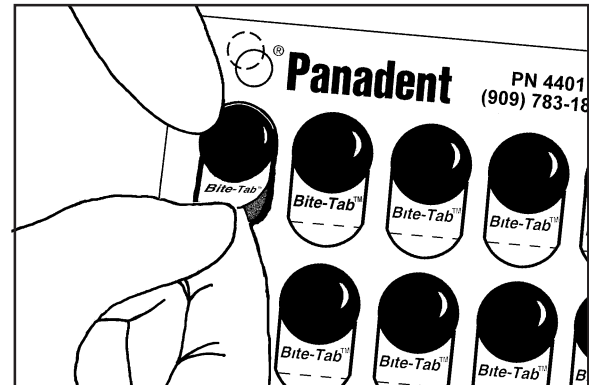

1

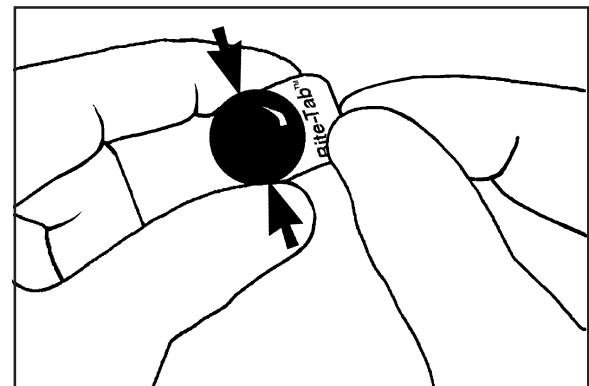

2

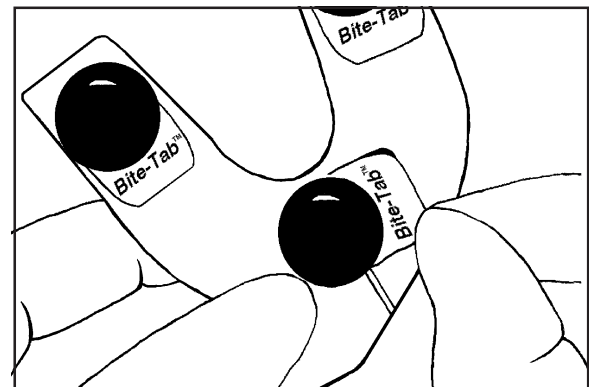

3

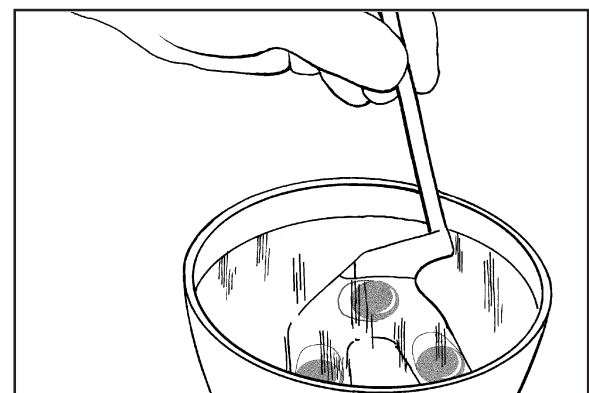

4

Face-Bow Instructions

5

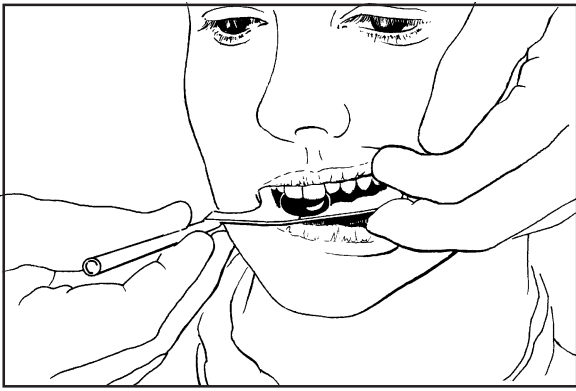

Place bite-fork in patient's mouth with stem on patient's right side and pointing straight forward. Position bite-fork with midline mark on fork aligned with midsagittal plane of head. Place mandible in retruded position. Instruct patient to close teeth with light pressure into the soft compound and open mouth immediately before teeth contact metal bite-fork. (Soft compound can be molded with fingers before placing in mouth for better contact with teeth if needed.)

6

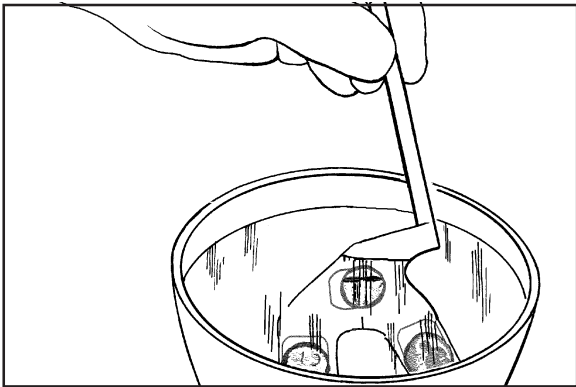

Remove bite-fork from patient's mouth and harden compound discs in cold water to quickly harden compound.

7

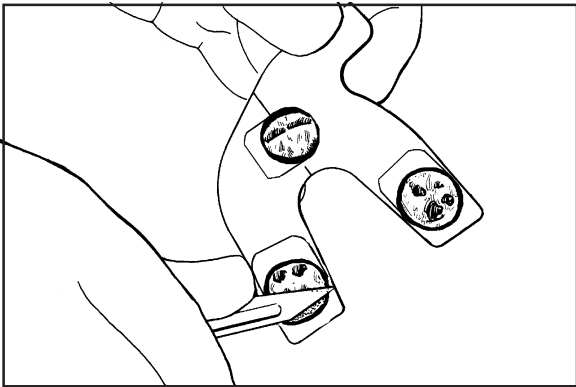

Shave back excess compound leaving no more than 1mm deep impressions of cusp tips and incisal edges. Also cut back any distal extension edentulous areas leaving only small area of ridge with dense attached gingiva to support bite-fork in the mouth. Remove all loose particles of compound with soft tooth brush or compressed air.

8

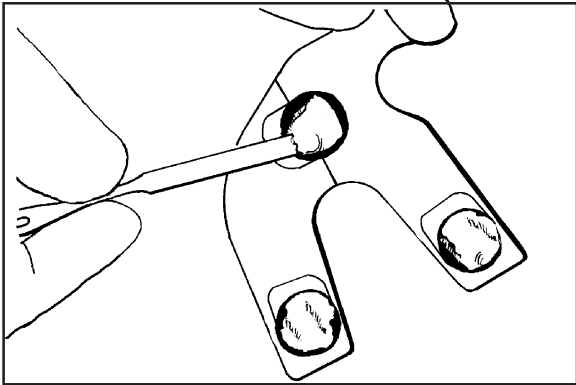

For highest accuracy, dry compound with air syringe. Place small amount of bite registration material on three compound pads on maxillary side only. (Include distal extension edentulous areas, if present.)

Face-Bow Instructions

Seat re-lined bite-fork registration against patient's maxillary teeth and have patient close mandibular teeth firmly into original indentations using lower jaw to support fork until bite paste hardens. (Operator's hands should be removed from bite-fork while reline material is hardening.)

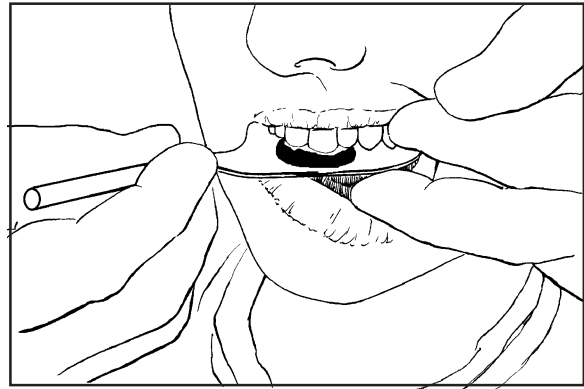

Lock nasion relator saddle with thumb screw forward against nasion relator bracket (top arrow). Slide nasion relator bracket completely onto face-bow cross-bar and lock in place with thumb screw (bottom arrow).

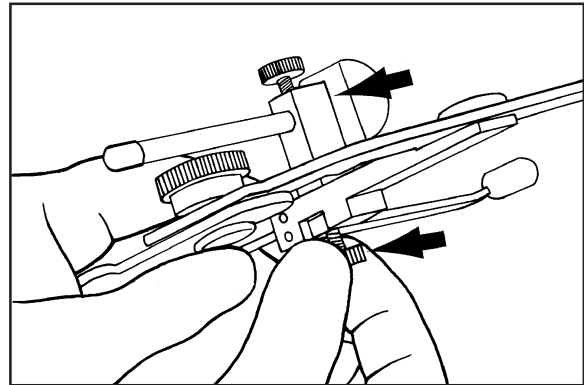

Position bite-fork attachment stem assembly with horizontal slide bar on patient's right side (arrow 1) and set-screw facing forward (arrow 2). Insert "short end" of attachment post into cross bar of face-bow completely to ring stop (upper end of post should be flush with upper surface of cross bar). Rotate attachment post until flat area on upper end faces forward to meet flat-ended set screw. Tighten set screw with hex wrench, to lock attachment post to cross-bar.

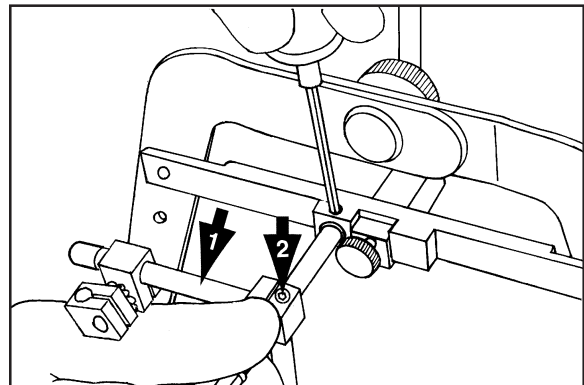

Loosen double-toggle clamp with hex wrench until both members of clamp are completely free to slide and/or rotate respectively.

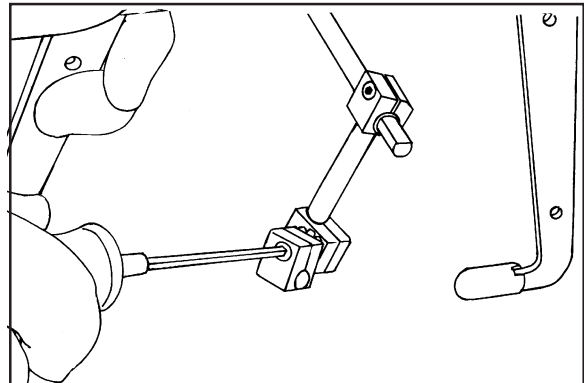

Face-Bow Instructions

13

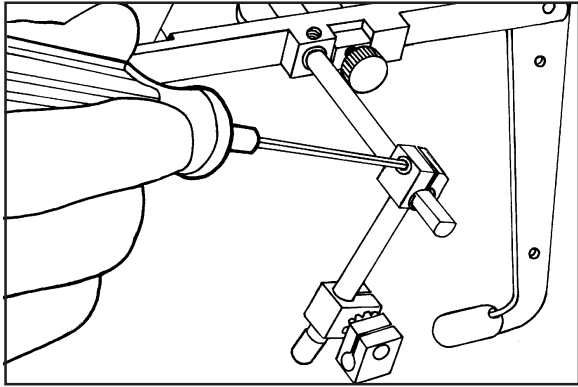

Loosen single toggle clamp with hex wrench until clamp slides freely up and down vertical attachment post.

14

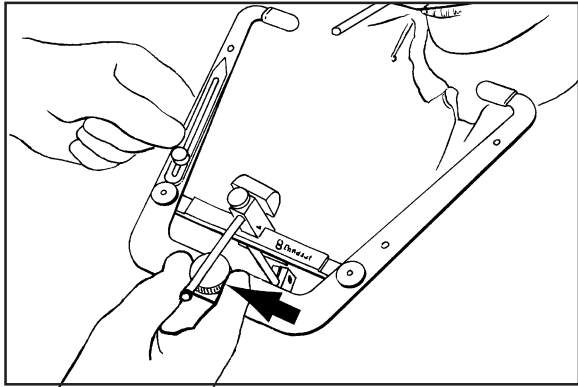

Slightly loosen (½ turn only) large thumb screw at anterior end of face-bow (arrow).

15

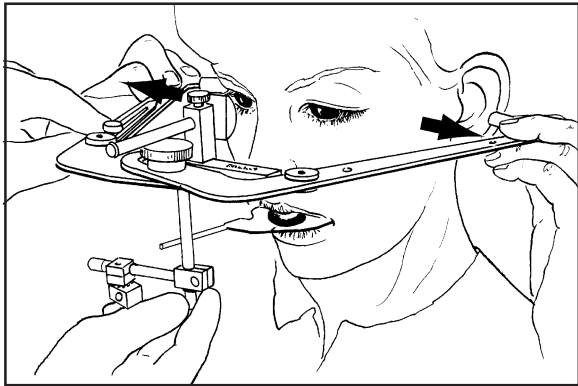

While operator holds anterior end of face-bow, have patient grasp side-arms of bow with his/her fingers near distal ends and extend bow to maximum width bilateral to face (arrows).

16

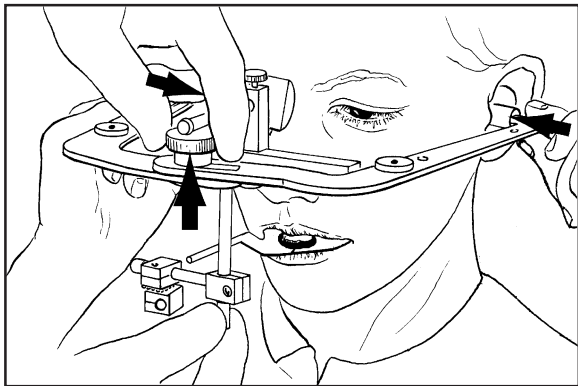

Instruct patient to contract side-arms and place ear pieces firmly in auditory meatuses (bilateral horizontal arrows). While patient keeps side-arms firmly in contact with ears, tighten large thumb screw (vertical arrow) to lock face-bow width.

Note: Attachment post clamp is not joined to protruding stem of bite-fork at this time.

Face-Bow Instructions

Loosen nasion relator shaft thumb screw slightly. While patient continues to support side-arms, raise or lower anterior end of face-bow until nasion-relator saddle can be made to contact patient's nasion area. Push firmly back with finger of one hand on end of nasion relator shaft while concurrently pulling forward with fingers on nasion support bracket (reciprocal arrows). Lock nasion relator saddle in firm contact against bridge of patient's nose (nasion).

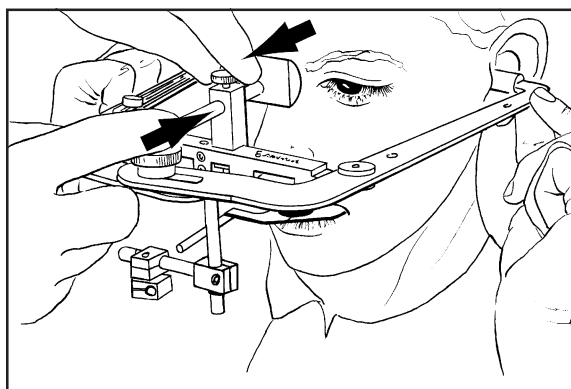

17

Have patient sit upright with head held perfectly erect and looking straight forward (Panadent Bio-Esthetic level guage can be added. (See Level Gauge Instructions)

While patient continues to support both side arms firmly, slide double-toggle clamp over protruding stem of bite-fork. (It is recommended to slide the clamp close to the patients mouth to reduce as much flexion of the components as possible.) Grasp double clamp (to offset torque) and tighten clamp securely to stem of bite-fork with hex wrench.

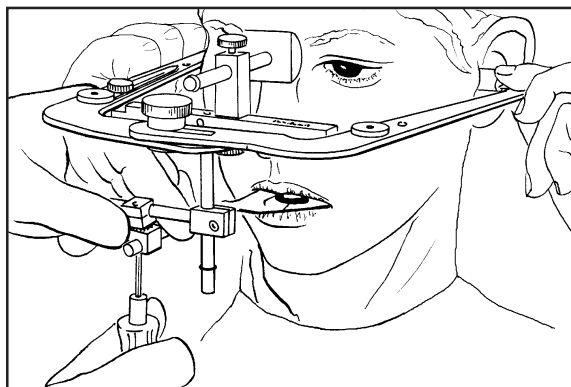

18

While patient continues to hold head erect and face-bow level, grasp single-toggle clamp tightly (to offset torque) and tighten clamp securely to vertical attachment post with hex wrench.

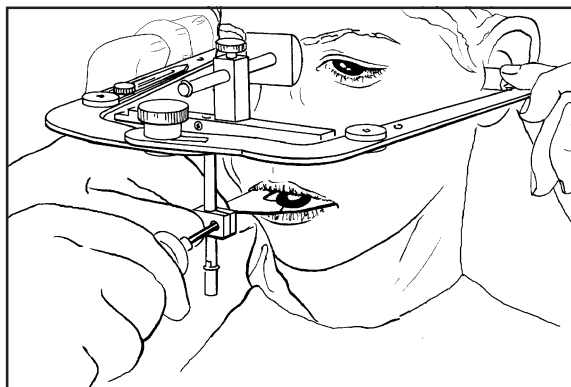

19

Loosen nasion relator thumb screw slightly and retract nasion relator away from patient's face. Lock nasion relator in contact with support bracket (arrow).

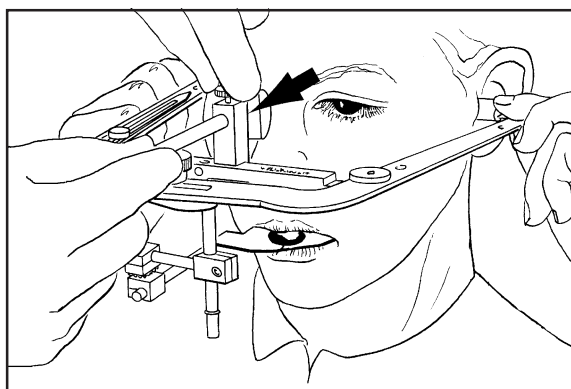

20

Face-Bow Instructions

21

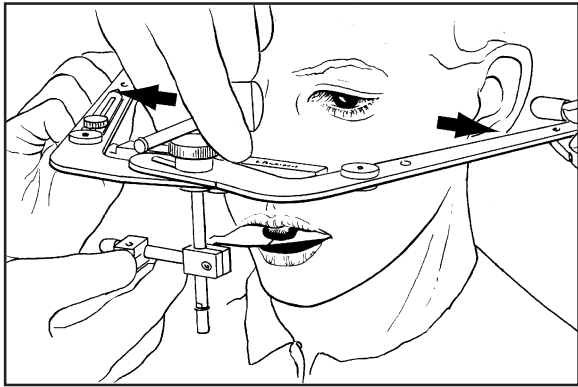

Slightly loosen ($\frac{1}{2}$ turn only) large thumb screw. Have patient open mouth and retract side-arms completely away from ears (arrows).

22

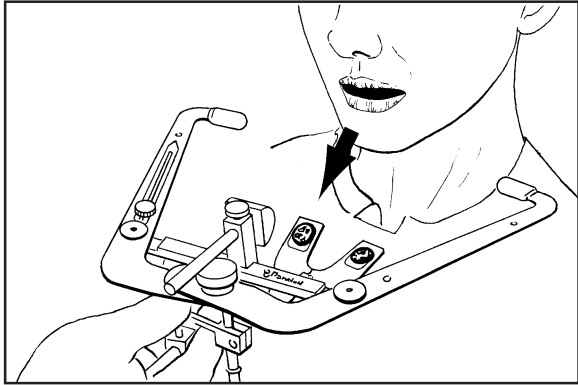

Instruct patient to remove their hands from face-bow and open their mouth. Remove face-bow downward and forward from patient's face (arrow).

23

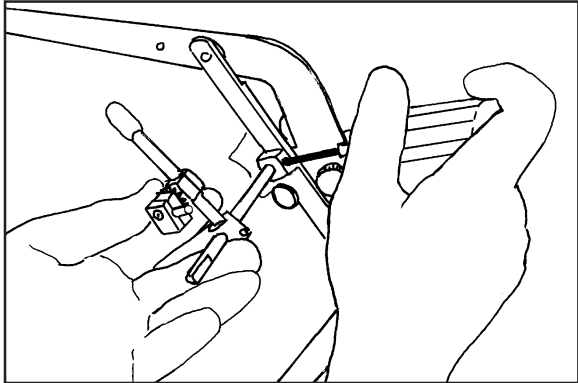

Loosen hex head set screw ($\frac{1}{2}$ turn only) on face-bow cross bar in preparation for removing bite-fork assembly.

24

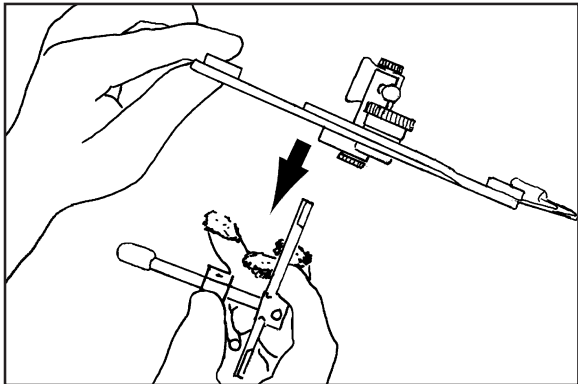

Remove bite-fork assembly straight downward (arrow). Transport bite-fork assembly to laboratory for cast mounting procedure. (*By having multiple bite-fork assemblies, face-bow can immediately be used for other patients.*)

Maxillary Cast Mounting Instructions

The Bennett size and angular rotational setting of the Panadent motion analog is not critical for mounting procedures since the motion analogs are all interchangeable in centric relation.

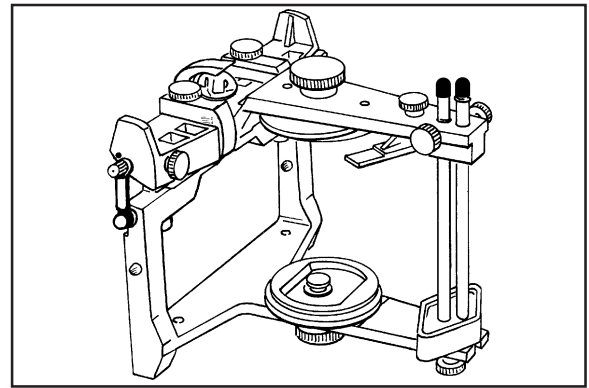

1

When using standard mounting plates on both maxillary and mandibular articulator frames, rotate mounting plates in direction thumb screw is being tightened so the plates will have perfect repeatability when replaced after cast mounting procedure.

Note: This procedure is not necessary if the Panadent magnetic mounting plate system is being used. (See Magna-Split II Instructions)

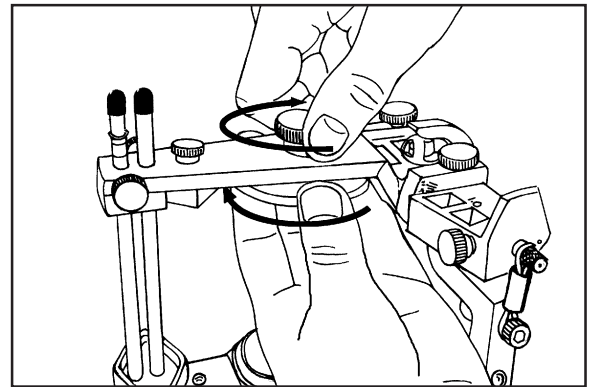

2

Slightly loosen right and left axis shaft lock screws with hex wrench.

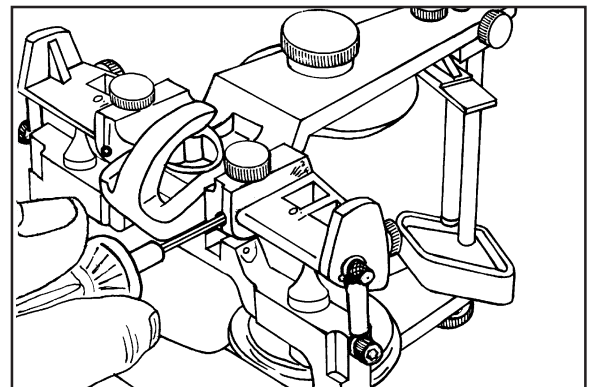

3

Slightly loosen right and left axis shaft thumb screws. Be sure motion analogs contact calibrated sides of articulator (arrow). Rotate motion analogs until #6 horizontal line coincides with superior surface of analogs, then tighten axis shaft thumb screws to maintain positions temporarily.

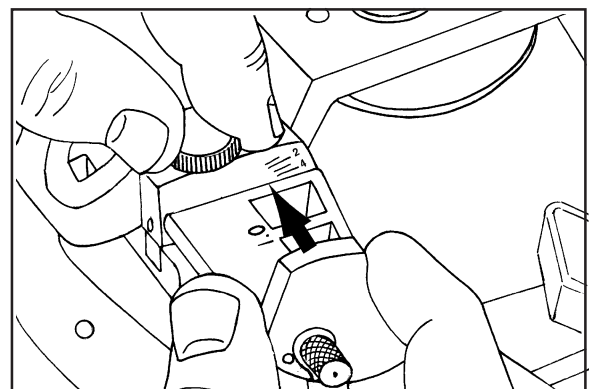

4

Maxillary Cast Mounting Instructions

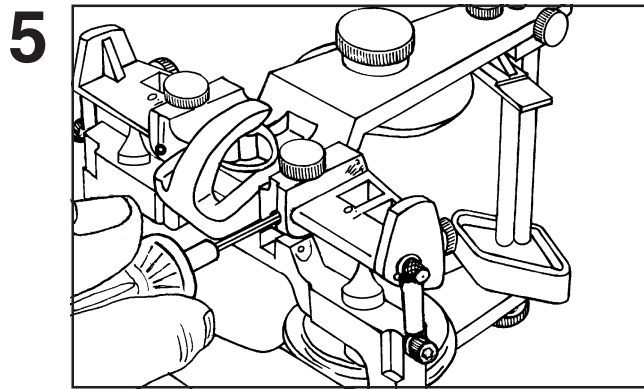

After analogs have been set at average angulation of "6", retighten right and left axis shaft lock screws with hex wrench.

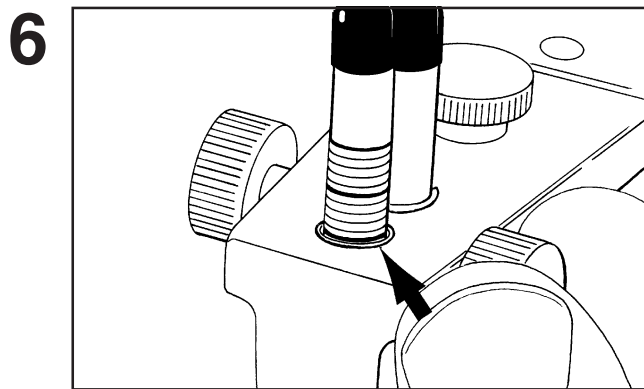

Set incisal pin at heavy center engraved ring (arrow). This will make the maxillary and mandibular articulator frames parallel to each other.

Note: If curved pin articulator is being used, set incisal pin at '0' degrees.

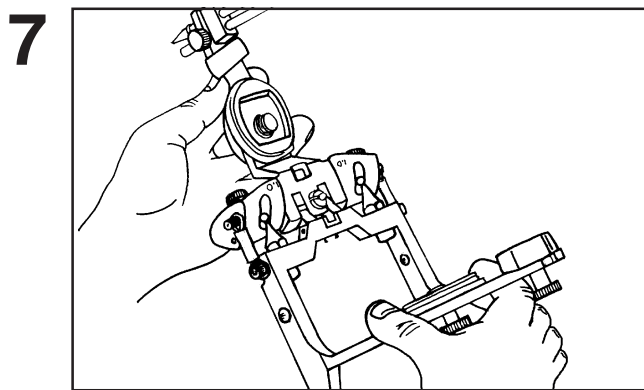

Open articulator by hinging maxillary frame back.

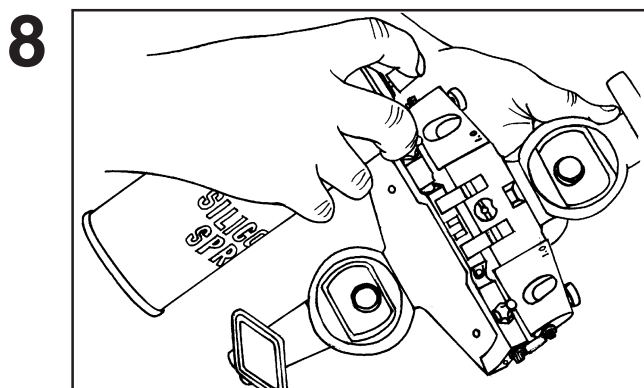

Spray entire articulator, including analogs, lightly with silicone lubricant spray each time before mounting casts to prevent mounting stone from sticking to articulator.

(The lubricant will cause residual mounting stone on articulator to be easily wiped off without scratching finished surface of instrument.)

Note: A vaseline or silicone gel on a cotton swab should be used each time to lubricate the analog paths and reduce wear on the analogs and condylar axis elements.

Maxillary Cast Mounting Instructions

Rotate maxillary frame back 180°. Extend and lock support post with thumb screw.

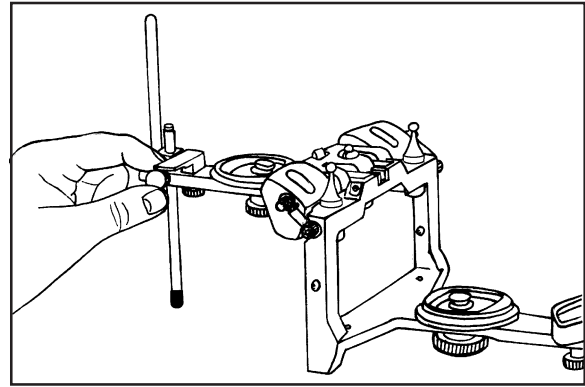

Slightly loosen incisal table thumb screw and remove table forward (arrow).

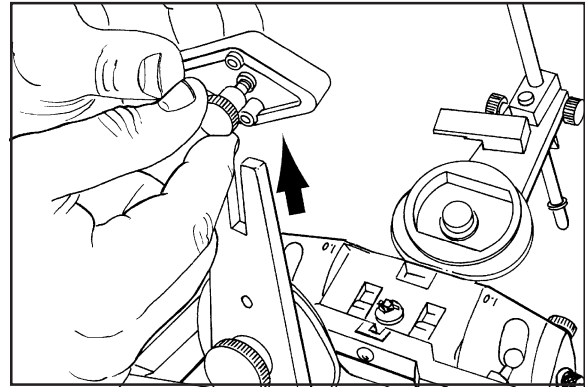

Place mounting fixture in incisal table slot and lock in rear most position (arrow) with thumb screw. When using the bi-mount fixture (#4054 ME) use high end of fixture for "H" model articulators and low end for mounting on "L" model articulators.

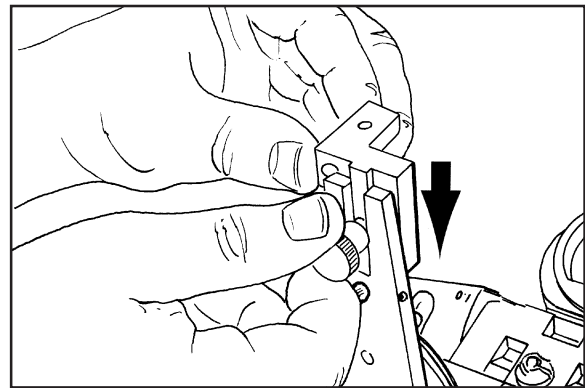

Cut back excess compound and/or zoe reline material from maxillary side of bite-fork. Include all soft tissue imprints except selected ridge areas used to support an edentulous area. Leave impressions of cusp tips approximately 1mm deep.

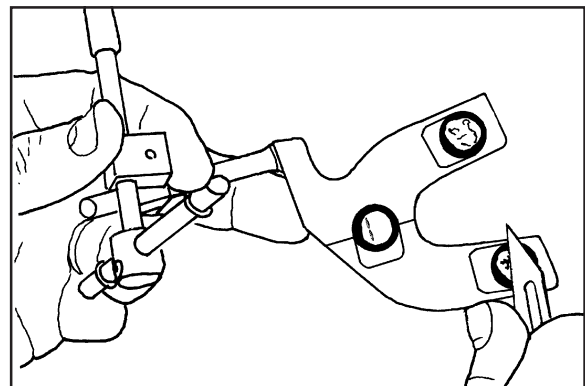

Maxillary Cast Mounting Instructions

13

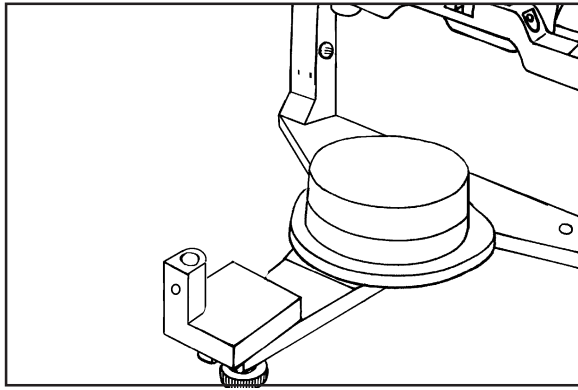

Place pre-made plaster bite-fork support (shown) or Panadent Magnetic Bite-Fork Support on lower frame of articulator to support maxillary cast.

(See Magnetic Bite Fork Support Instructions)

14

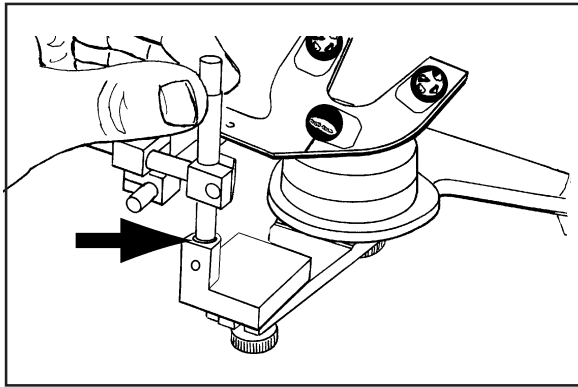

Hold upper end of bite-fork attachment post with thumb and index finger. Place lower end of bite fork post into vertical hole in mounting fixture. Seat post completely down to retaining ring (arrow) to determine how much plaster is needed to make contact with plaster bite-fork support. If plaster support is too high, reduce it with a model trimmer.

15

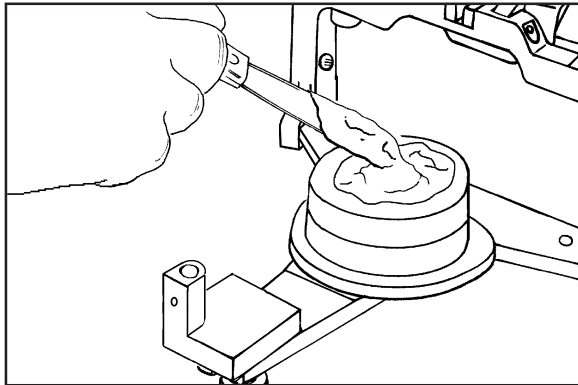

Remove bite-fork assembly. Place a sufficient quantity of soft quick set plaster on upper surface of bite-fork support column so that lower surface of bite-fork will be slightly imbedded in the soft plaster when bite-fork assembly is placed in mounting fixture.

16

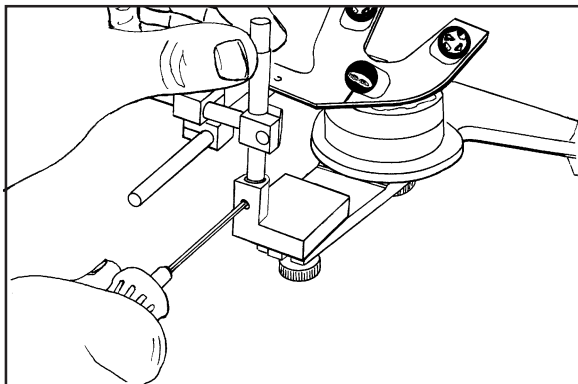

Hold upper end of bite-fork attachment post with thumb and index finger of one hand. Place lower end of attachment post into hole in mounting fixture. Be sure bite-fork attachment post is completely down to retaining ring stop. Tighten set screw with hex wrench (or fingers if 'T' head screw is being used). Remove hands and allow support plaster to harden undisturbed.

Maxillary Cast Mounting Instructions

With model trimmer, grind maxillary surface of cast parallel to occlusal plane of teeth. Grind perimeter of cast with approximately 10-15° bevel to depth of buccal and labial vestibules. Avoid touching teeth or buccal and labial gingival areas with trimmer wheel.

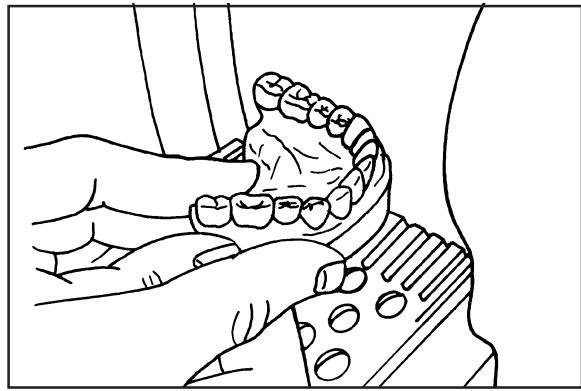

17

Score superior mounting surface and beveled areas of cast with laboratory knife or carborundum disc for retention in mounting stone.

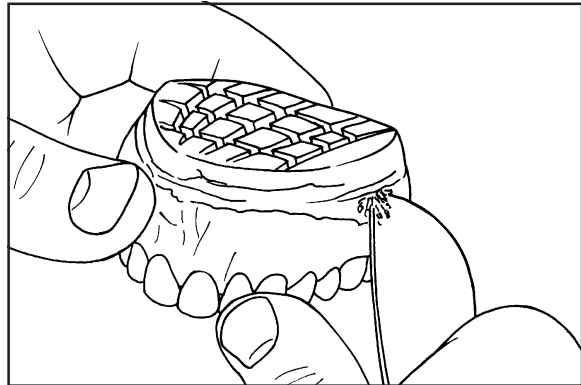

18

Remove all bubbles or impression defects from occlusal and incisal areas of casts.

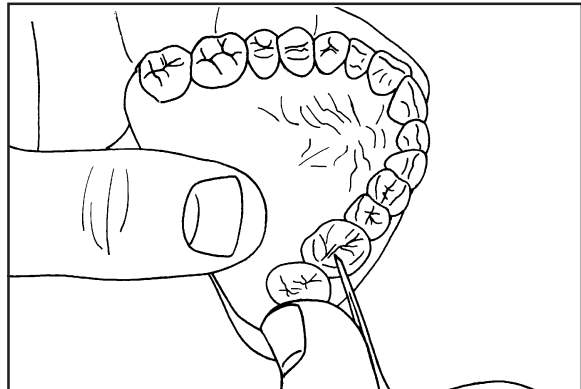

19

Seat cast carefully into bite fork registration and verify fit of cast to registration.

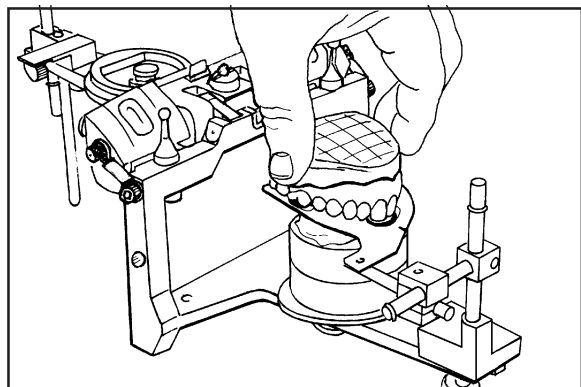

20

Maxillary Cast Mounting Instructions

21

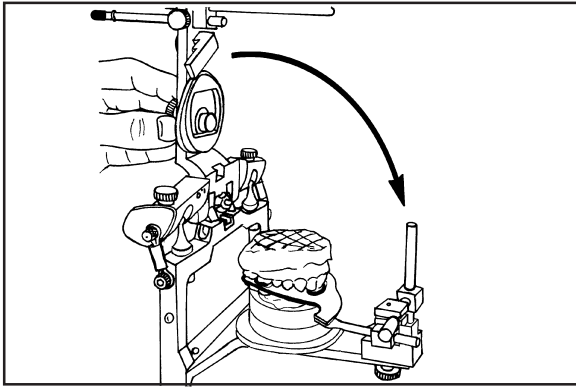

Hinge maxillary frame upward and forward over cast and bite fork assembly (curved arrow).

22

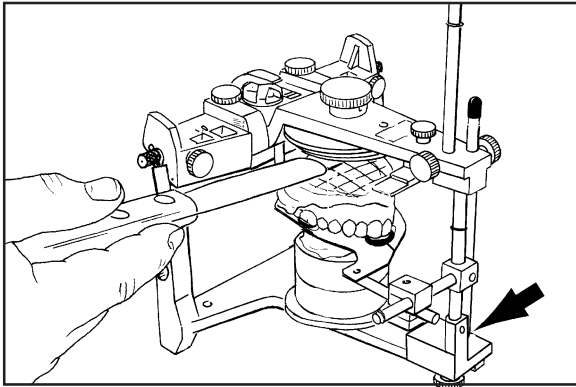

Close maxillary frame of articulator over cast until end of incisal pin contacts upper surface of mounting fixture (arrow). Determine quantity of mounting stone needed. Grind cast if necessary so there is at least 5mm space between cast and mounting plate in area indicated by spatula.

23

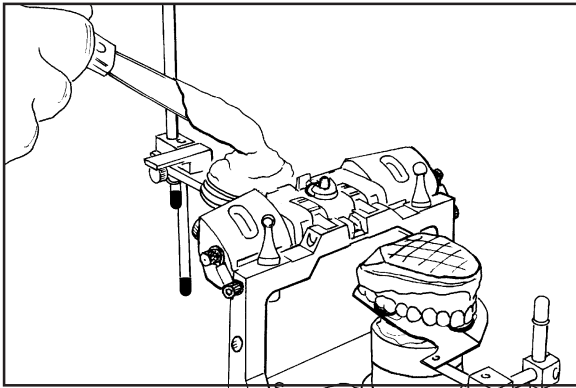

Hinge maxillary frame back 180°. Mix mounting stone to the consistency of whipped cream. Place stone first in retention areas of mounting plate.

24

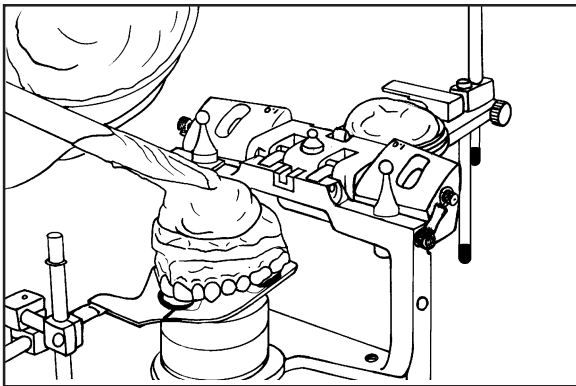

Place sufficient amount of soft stone on mounting surface of maxillary cast. (The amount of mounting stone should be only enough to make a "solid" connection with the mounting plate stone. Reinforcement stone can be added later after the initial stone has hardened.)

Maxillary Cast Mounting Instructions

Hinge maxillary frame forward to join the two pads of soft stone (curved arrow).

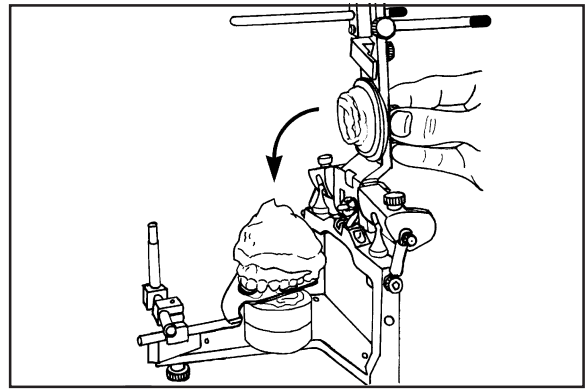

25

Close articulator until incisal pin contacts surface of mounting fixture (arrow).

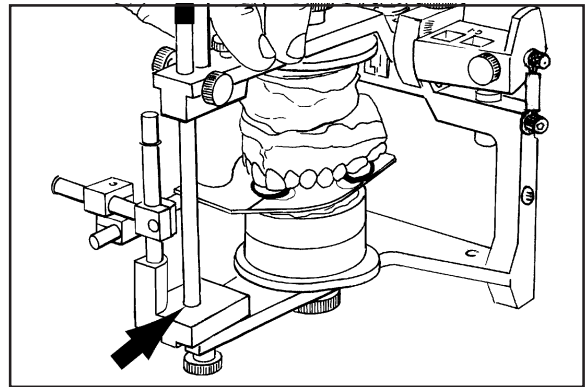

26

Remove any overhanging soft stone with spatula or finger carefully to avoid disturbing cast in bite fork registration. (Mounting stone should not extend beyond perimeter of mounting plate and vestibule of cast.) Leave cast undisturbed until mounting stone has completely hardened.

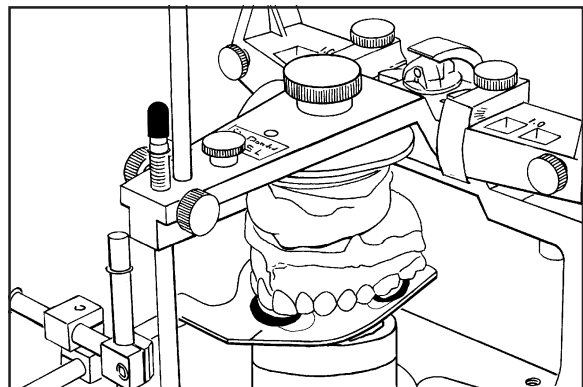

27

After mounting stone has hardened, release centric latch and rotate maxillary frame backward with cast attached (arrow).

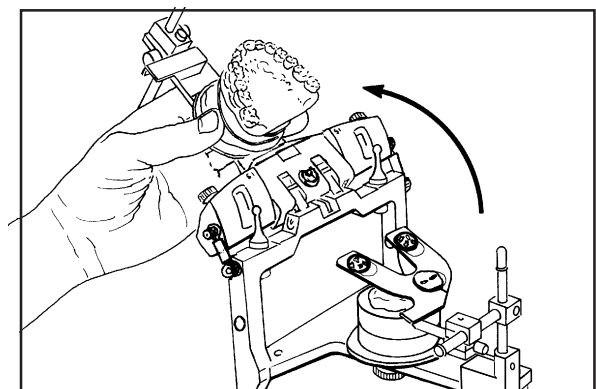

28

Maxillary Cast Mounting Instructions

29

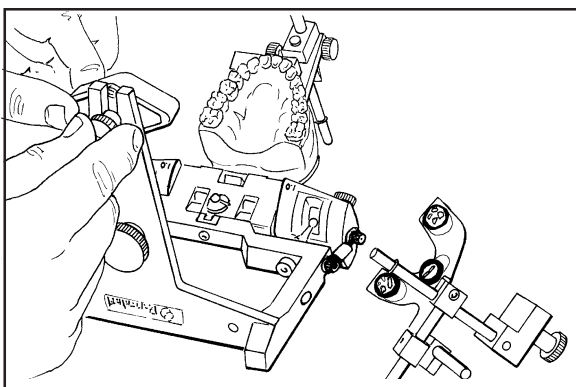

Remove mounting fixture, bite-fork assembly and bite-fork support. Replace incisal table.

30

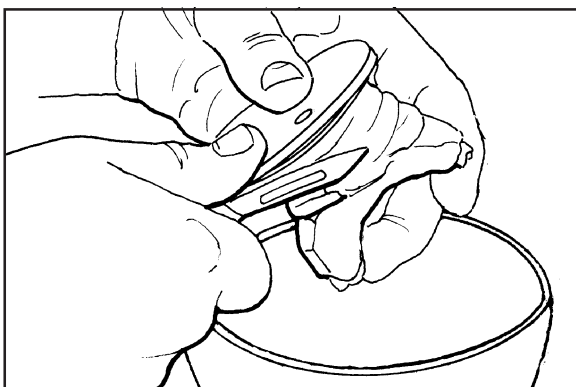

Remove maxillary cast from articulator. Cut back excess stone (if any) projecting beyond perimeter of mounting plate and vestibule of cast.

31

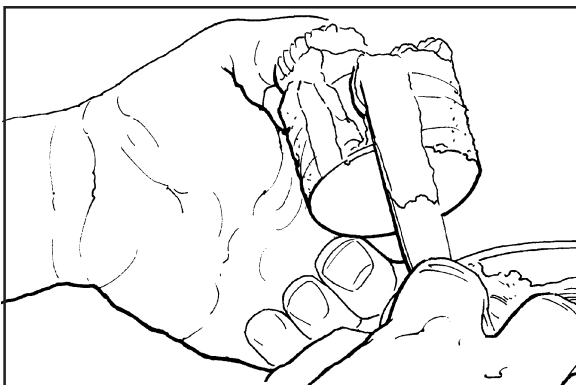

For more secure and esthetic mounting, mix quick-set plaster to the consistency of whipped cream. Add reinforcement layer of plaster to cast using trimmed edge of cast and perimeter of mounting plate as guides for plaster spatula. While plaster is still soft, use fingers under running tap water to smooth plaster surfaces.

32

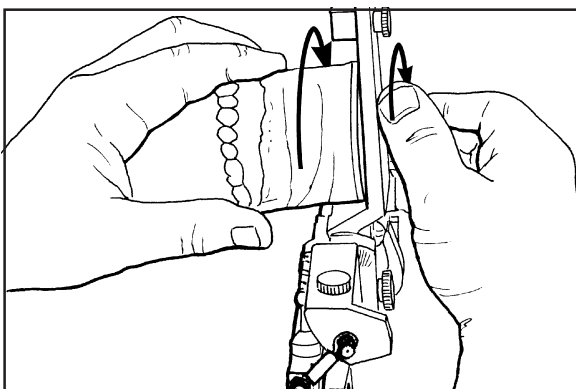

Remove any residual plaster from mounting plate and articulator before replacing cast on articulator. When standard mounting plates are being used be sure to rotate mounted cast in directions the mounting plate screw is being turned (arrows). Tighten mounting plate screw securely.